



BACK-UP ALARMS



450
only

400 SERIES Grommet Mount

The 400 Series back-up alarm features a reverse-mounted speaker design and utilizes a standard 4.5" rear lighting grommet for mounting directly into the vehicle body. Vehicle downtime is reduced as the alarm can be fitted or replaced quickly and easily without tools, there are no holes to drill and no bolts to tighten. Not only is the 'in-body' mounting method easier to install, but it also ensures the warning signal is projected where it is needed, directly into the hazard zone at the rear of the vehicle. Two models are available: 112dB(A) fixed decibel versions as well as an 87-112dB(A) Smart Alarm[®] unit.

ECCO's range of Smart Alarms measure ambient noise and adjust their sound level, creating a volume that is safe without being annoying or contributing to noise pollution. Smart Alarms eliminate the need for constant manual adjustment and help prevent intentional alarm disconnection.

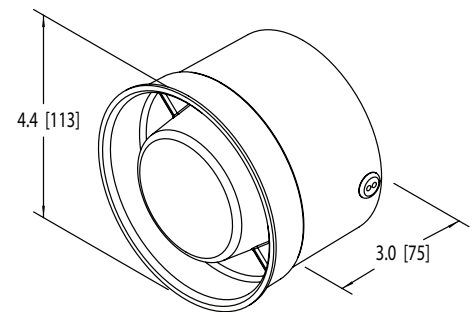

Models

PART NO.	TYPE	VOLTAGE	dB(A)	AMPS
SA940	Smart	12-24	87-112	0.6
450	-	12-36	112	0.4

Alarm Specifications

Connection: 16 AWG blunt cut wires
Housing: Fiberglass reinforced nylon
Mounting: 4.5" standard rear lighting grommet

Features and Benefits

- Grommet mount reduces installation time and directs warning to rear of vehicle
- For use with standard 4.5" rear-lighting grommet (order separately)
- Epoxy sealed for protection against dust, moisture and vibration
- Temperature Range: -40°F to +185°F (-40°C to +85°C)

Parts & Accessories

- Mounting Grommet: R2140GR

